

USN									
-----	--	--	--	--	--	--	--	--	--

18ME36A/18MEA306/18MA36

Third Semester B.E. Degree Examination, August 2020

COMPUTER AIDED MACHINE DRAWING

Time: 3 Hours

Max. Marks: 100

Note: 1. Answer any one question from each of the parts A,B,C

2. Use **FIRST ANGLE** projection only.

3. Missing data if any may suitable be assumed

4. All the calculations should be on answer sheet supplied

5. All the dimensions are in mm

6. **Part C Assembled View should be in 3D and the other 2 views in 2D****PART-A**

Q. No. 1 A cube of 40mm side is cut by a sectional plane, so that the true shape of section is an equilateral triangle of sides of maximum length. Draw the sectional top view and true shape of section. Determine the inclination of the plane to HP and measure the length of the sides of the equilateral triangle.

(25 Marks)

Q. No. 2 Draw the conventional form of following threads for pitch 30 mm at least 3 threads in each form: a) Acme thread b) Seller's thread.

(25 Marks)**PART-B**

Q. No. 3 Draw two views of socket and spigot cotter joint of diameter of shaft 25mm.

(25 Marks)

Q. No. 4 Draw two views of a flanged coupling (Protected type) of diameter of shaft of 30mm.

(25 Marks)**PART-C**

Q. No. 5 Figure: 1 Shows the details of "Plummer block". Assemble the parts and draw the following: a) Sectional front view b) Top view

(50 Marks)

Q. No. 6 Figure: 2 Shows the details of "I C Engine of Connecting rod". Assemble the parts and draw the following: a) Sectional front view b) Top view

(50 Marks)

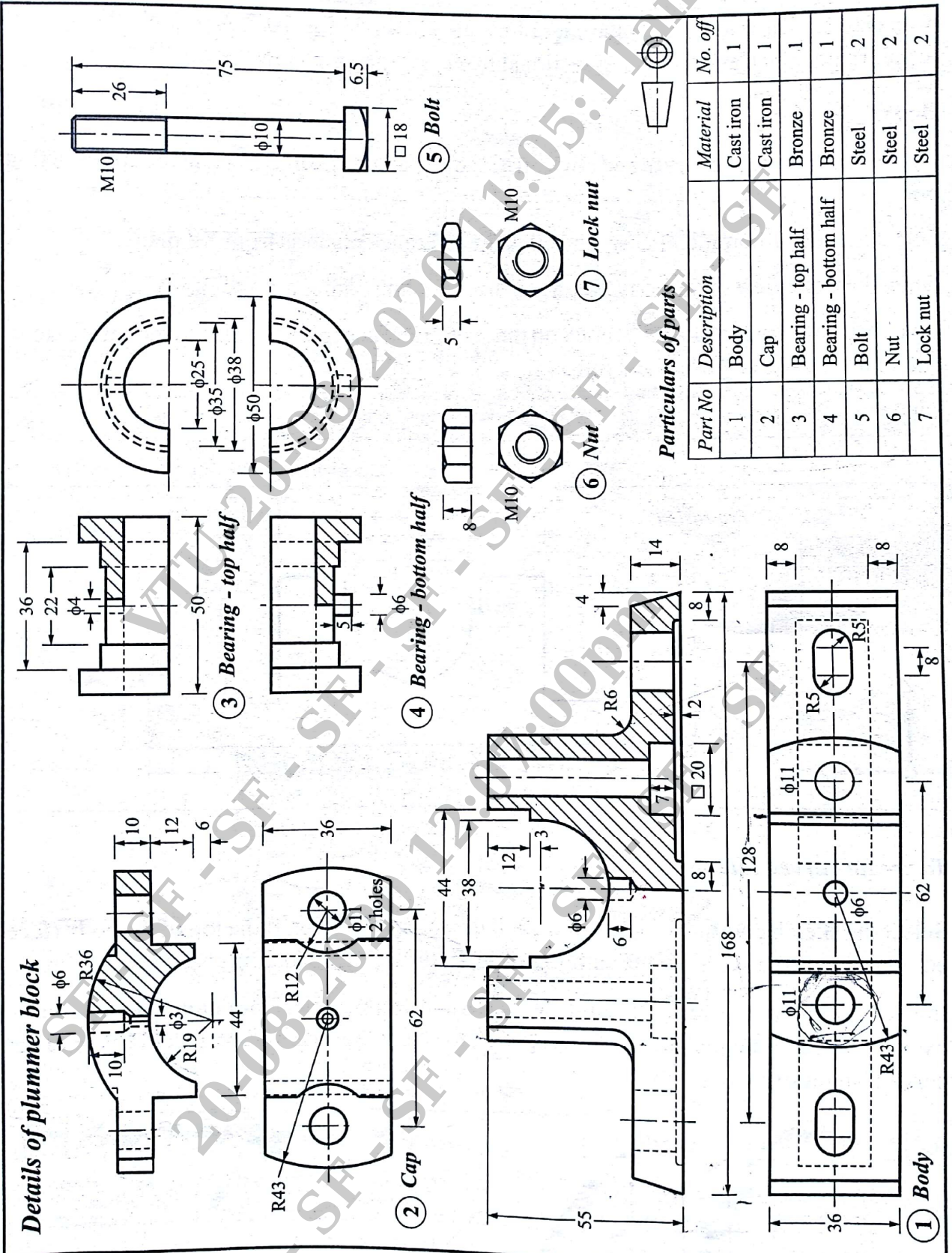

Figure 1: Details of Plummer Block

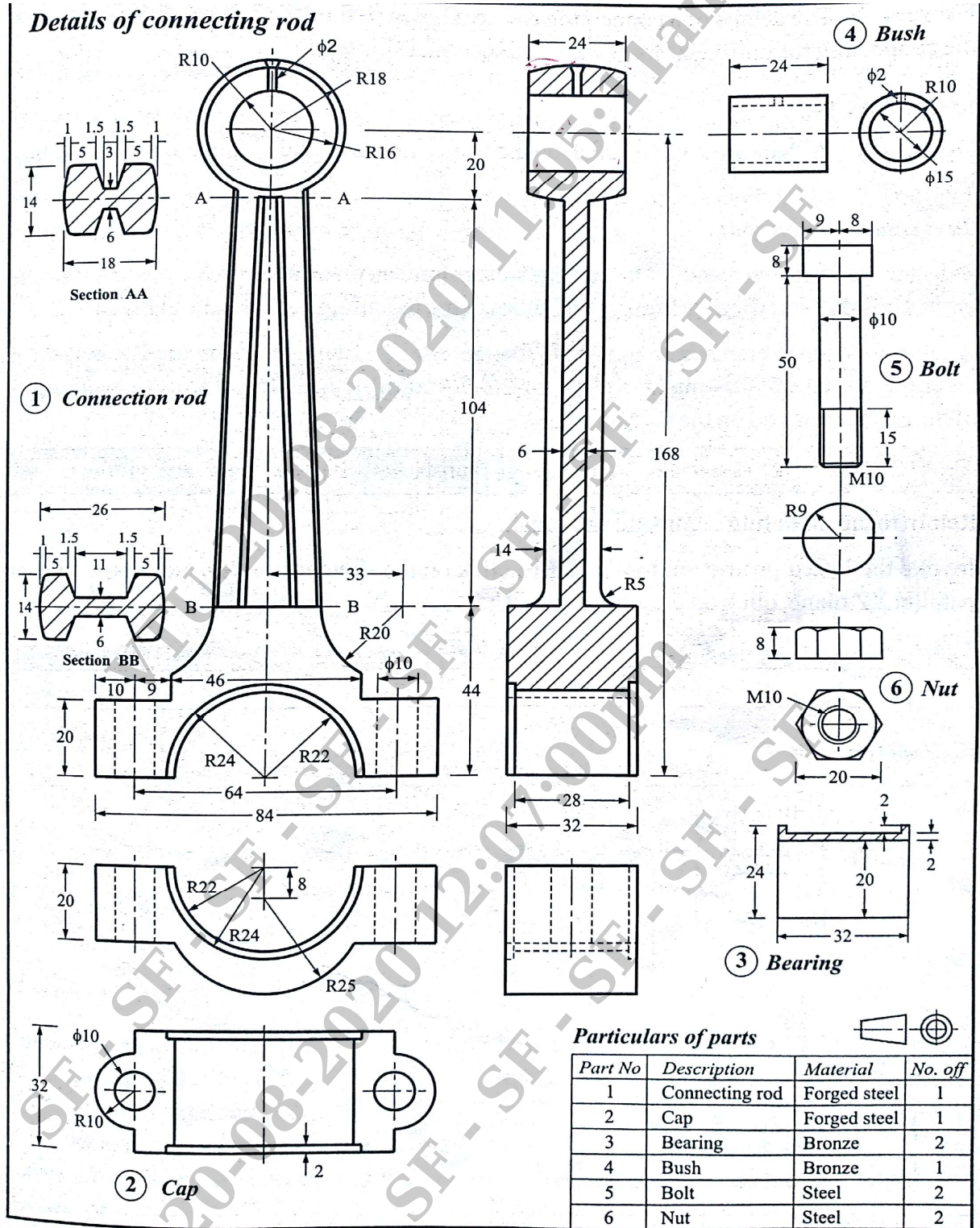

Figure 2: Details of Connecting rod